

10GBASE-T Copper SFP+ Transceiver Module, Cat6A/Cat7, 10m, RJ-45

10GBASE-T Copper SFP+ Transceiver Module, Cat6A/Cat7, 10m, RJ-45

Features

- Hot-pluggable SFP+ footprint
- Supports Links up to 10m using Cat 6a/7 Cable
- Compliant with IEEE 802.3az
- Compliant with SFF-8431 and SFF-8432 MSA
- Low Power Consumption (2.5W MAX @ 30m)
- Auto-negotiates with other 10GBase-T PHYs
- I2C 2-Wire Interface for Serial ID and PHY Register Access
- Auto-sense MDI/MDIX
- RoHS compliant and lead-free
- Operating Temperature: 0~70°C



Applications

- 10G Ethernet over category 6a/7 twisted-pair copper cabling
- Enterprise data centers and server consolidations
- Low-cost campus backbones

Description

10GBASE-T SFP+ Copper transceiver is specifically designed for high speed 10 Gigabit Ethernet communication over Cat 6a / Cat7 cable. It is compliant with the Multi-Source Agreement (MSA) and 10GBASE-T, 5GBASE-T, 2.5GBASE-T, 1000BASE-T standards as specified in IEEE STD 802.3an, 802.3ab and 802.3au. The 10G copper SFP+ transceiver allows IT designers and data center professionals to extend the distance of 10GbE Ethernet links over an existing copper cabling infrastructure. The copper module provides convenience, flexibility and cost savings for deploying 10 Gb/s technology over balanced twisted-pair copper cabling. More important, the 10GBASE-T SFP+ transceiver automates interoperability with legacy Ethernet devices and backward compatible with legacy 1000Base-T networks. This helps end users to protect their investment in existing copper cabling infrastructure.

Absolute Maximum Ratings

Parameter	Symbol	Min	Max	Unit	Notes
Maximum Supply Voltage	Vcc	-0.5	4.0	V	
Storage Temperature	T _s	-40	85	°C	
Operating Humidity	RH	5	85	%	

General Specifications

Parameter	Symbol	Min	Typ	Max	Unit	Notes
Data Rate	DR		10		Gbps	1
Cable Length	CL		10		meter	2
Bit Error Rate	BER			10 ⁻¹²		

Supply Current	IS		700	750	mA	3
Input Voltage	V _{CC}	3.13	3.3	3.47	V	4
Maximum Voltage	V _{MAX}			4	V	
Surge Current	I _{surge}			30	mA	5

Note :

1. IEEE 802.3
2. Cat 6a/7 UTP
3. For electrical power interface
4. Referenced to GND
5. Hot Plug above steady state current

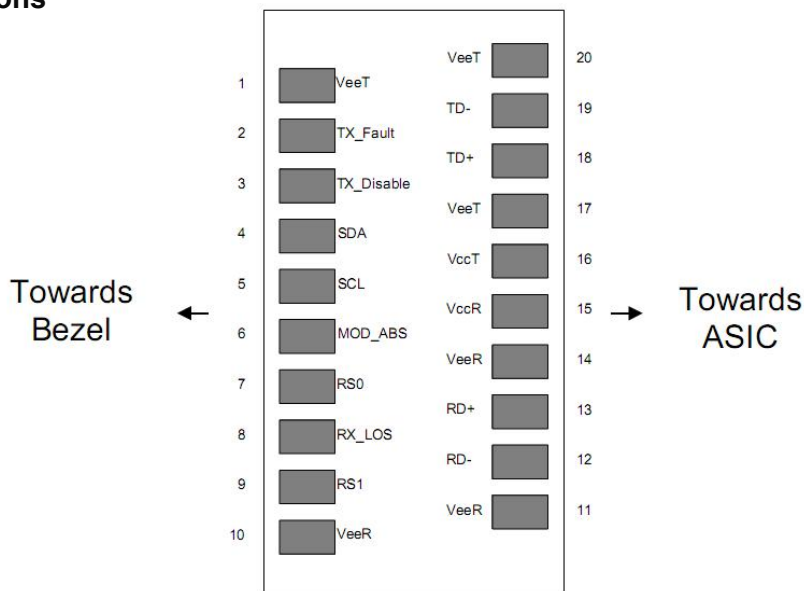
Pin Definitions**Pin Descriptions**

Pin	Signal Name	Description	Plug Seq.	Notes
1	V _{EET}	Transmitter Ground	1	
2	TX_FAULT	Transmitter Fault Indication	3	Note 1
3	TX_DISABLE	Transmitter Disable	3	Note 2
4	SDA	SDA Serial Data Signal	3	
5	SCL	SCL Serial Clock Signal	3	
6	MOD_ABS	Module Absent. Grounded within the module	3	
7	RS0	Not Connected	3	
8	RX_LOS	Loss of Signal indication. Logic 0 indicates normal operation.	3	Note 3
9	RS1	Not Connected	3	
10	V _{EER}	Receiver ground	1	
11	V _{EER}	Receiver ground	1	
12	RD-	Inv. Received Data Out	3	Note 4

13	RD+	Received Data Out	3	Note 4
14	V _{EER}	Receiver ground	1	
15	V _{CCR}	Receiver Power Supply	2	
16	V _{CCT}	Transmitter Power Supply	2	
17	V _{EET}	Transmitter Ground	1	
18	TD+	Transmit Data In	3	Note 5
19	TD-	Inv. Transmit Data In	3	Note 5
20	V _{EET}	Transmitter Ground	1	

Notes:

Plug Seq.: Pin engagement sequence during hot plugging.

1. TX Fault is an open collector output, which should be pulled up with a 4.7k~10kΩ resistor on the host board to a voltage between 2.0V and V_{cc}+0.3V. Logic 0 indicates normal operation; Logic 1 indicates a laser fault of some kind. In the low state, the output will be pulled to less than 0.8V.
2. Laser output disabled on TDIS >2.0V or open, enabled on TDIS <0.8V.
3. LOS is open collector output. Should be pulled up with 4.7k~10kΩ on host board to a voltage between 2.0V and 3.6V. Logic 0 indicates normal operation; logic 1 indicates loss of signal.
4. RD-/+ : These are the differential receiver outputs. They are internally AC-coupled 100 differential lines which should be terminated with 100Ω (differential) at the user SERDES.
5. TD-/+ : These are the differential transmitter inputs. They are internally AC-coupled, differential lines with 100Ω differential termination inside the module.

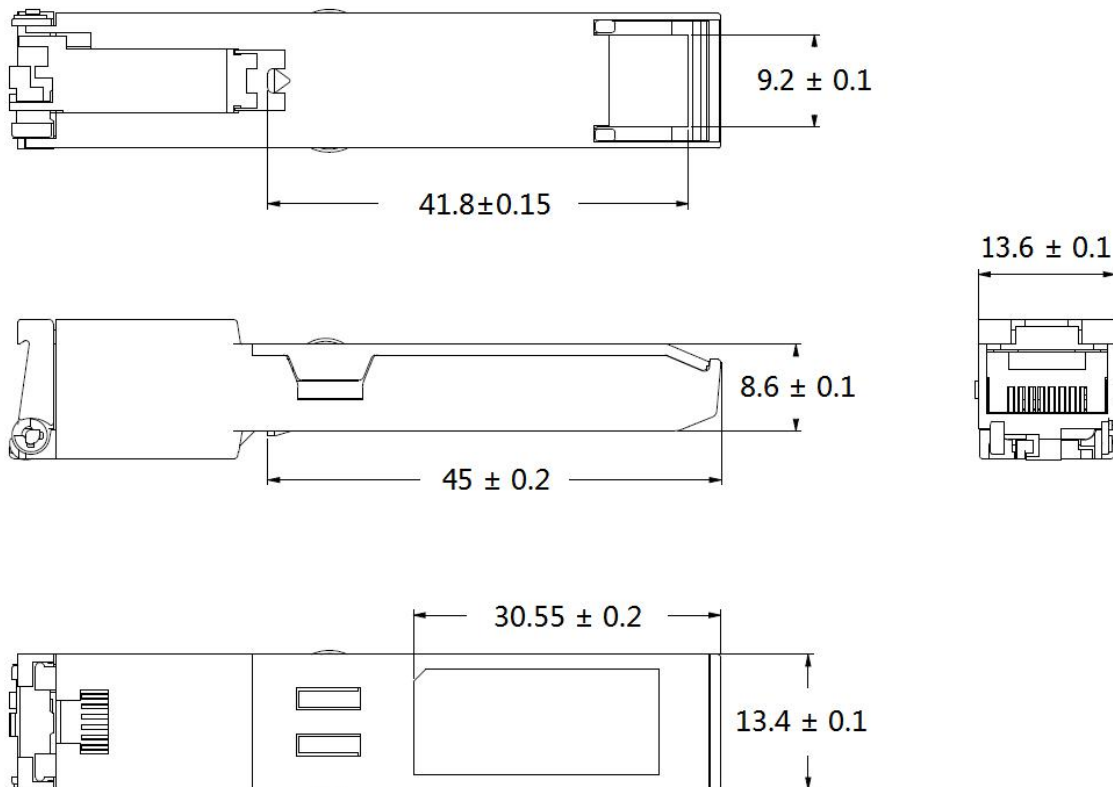
Mechanical Dimensions

Ordering information

Part number	Description
SFPP-T 1000000000	10GBASE-T Copper SFP+ Transceiver, Cat6A/Cat7, 1000000000 m, RJ45, 0°C~+70°C

Warnings***Process plug***

The transceiver optics is supplied with a dust cover. This plug protects the transceiver optics during standard manufacturing processes by preventing contamination from air borne particles. It is recommended that the dust cover remain in the transceiver whenever an optical fiber connector is not inserted.

Handling Precautions

The transceiver optics is susceptible to damage as a result of electrostatic discharge (ESD). A static free environment is highly recommended. Follow guidelines according to proper ESD procedures.

Laser Safety

The transceiver optics is a Class 1 laser product per international standard IEC 60825-1. Radiation emitted by laser devices can be dangerous to human eyes. Avoid eye exposure to direct or indirect radiation.